







Thank you for purchasing a *Discgear® 100 auto*. Please take time to get to know your *100 auto* and it's many great benefits. Then fill your *100 auto* with your favorite discs.

Know your *Discgear® 100 auto*

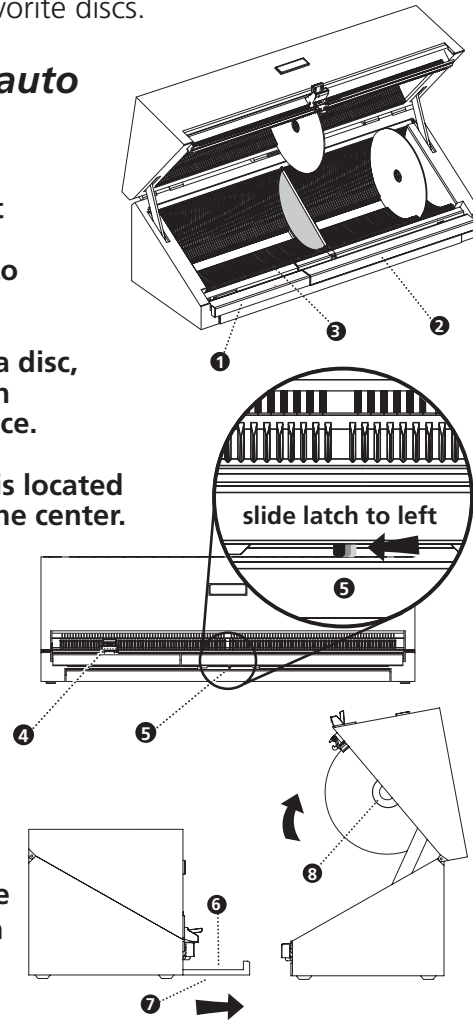
- 1 Title sheet access bar 
- 2 Disc-selector bar  - Opens unit
- 3 Self-aligning slots - Allow you to easily roll the disc into the slot.
- 4 Disc-selector button - To select a disc, push down and slide the button to the disc number of your choice.
- 5 Hidden lock - The hidden latch is located under the disc-selector bar, in the center. To lock the *100 auto*, slide the hidden latch to the left.
- 6 Title sheet - To access the title sheet, press on the title sheet access bar .
- 7 Title sheet tray
- 8 Disc-numbering pen - Use the enclosed pen to number each disc so the storage slots and the title sheet match. Now you can easily return each disc to it's number slot.



100 auto Instructions

- Organize your discs.** Choose one of these methods:
 - 1) Visit www.discgear.com to access **Discware™ Online**, our online service for cataloging and organizing your discs, and printing title sheets.
 - 2) Remove title sheet from the plastic sleeves located in the sheet tray. Write your disc titles directly on the title sheet.
- Access your title sheet.** Press on the title sheet access bar  and the title sheet tray will automatically appear. Insert your title sheet between the plastic sleeves. Make your selection.
- Number your discs.** Use the enclosed disc numbering pen to reference your disc's slot number. Use an alpha-numeric system so you can organize multiple disc-storage units (Ex. A1, B1, C1). *We recommend that you only write on the clear center ring on the front of the disc.*
- Fill your 100 auto.** As you number each disc, place it in the corresponding slot number.
- Select your disc.** Press the disc-selector button and slide it to the desired numbered slot. Release, then press the disc-selector bar  and your *100 auto* automatically retrieves your disc.
- Replace your discs.** Refer to the number on your disc, find the appropriate "self-aligning slot" and roll the disc back into location.

NOTE: Use our Literature Album (not included) to store and organize your DVD & CD literature. For more information: www.discgear.com.

www.discgear.com

©2008 CD3, Inc. All rights reserved. Discgear and CD3 are registered trademarks of CD3, Inc.

CD3, Inc.

15505 Long Vista Drive
Suite 250
Austin, TX 78728